

ANCHOR BOLTS PLAN
 (REF DWG: S1.0)

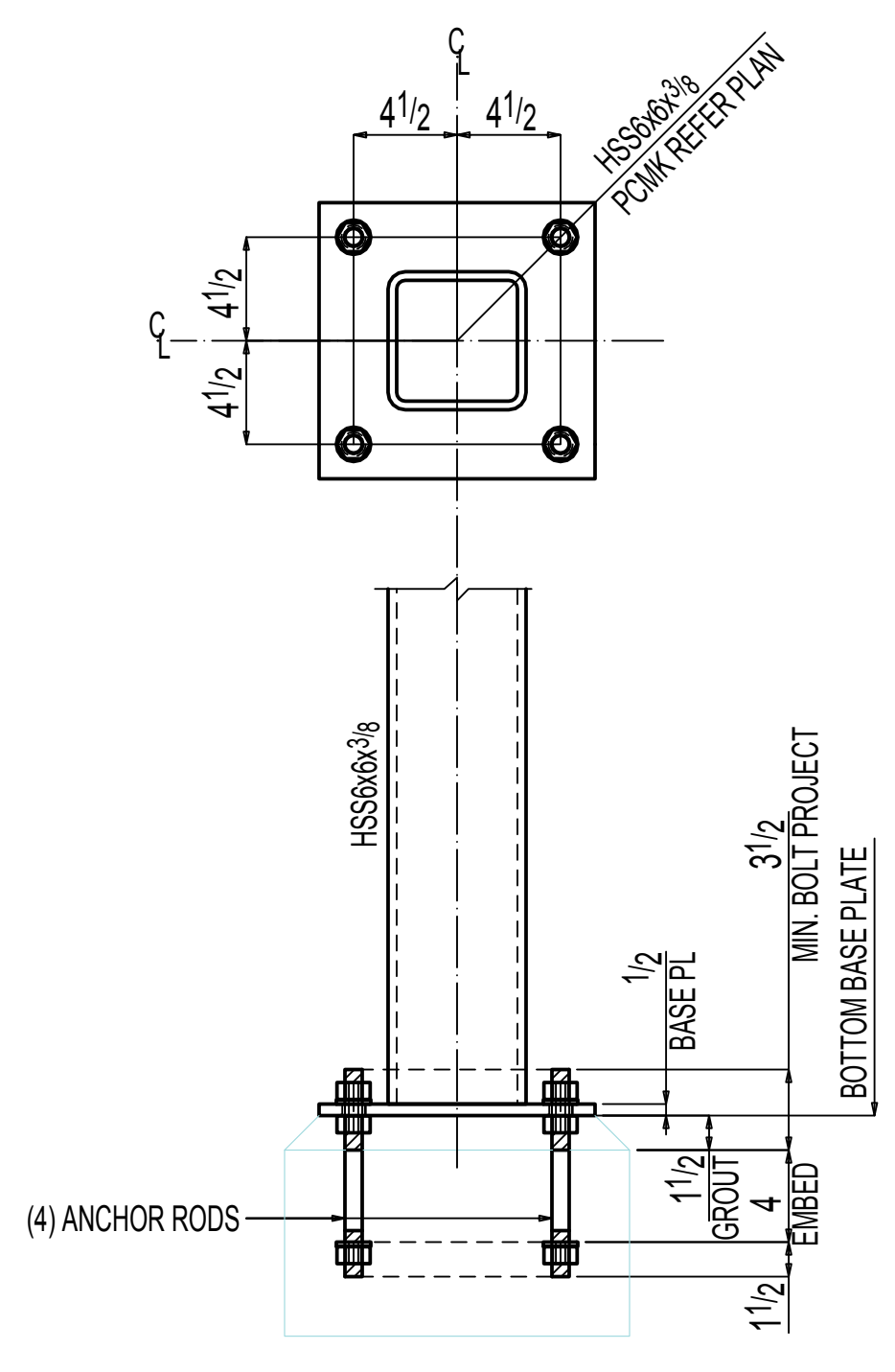

ANCHOR ROD SETTING TYPE

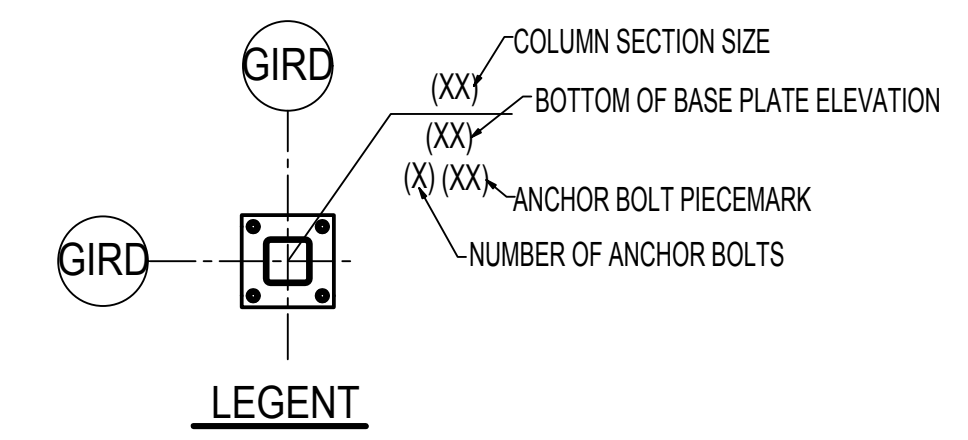
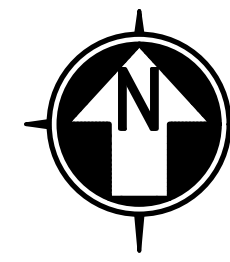
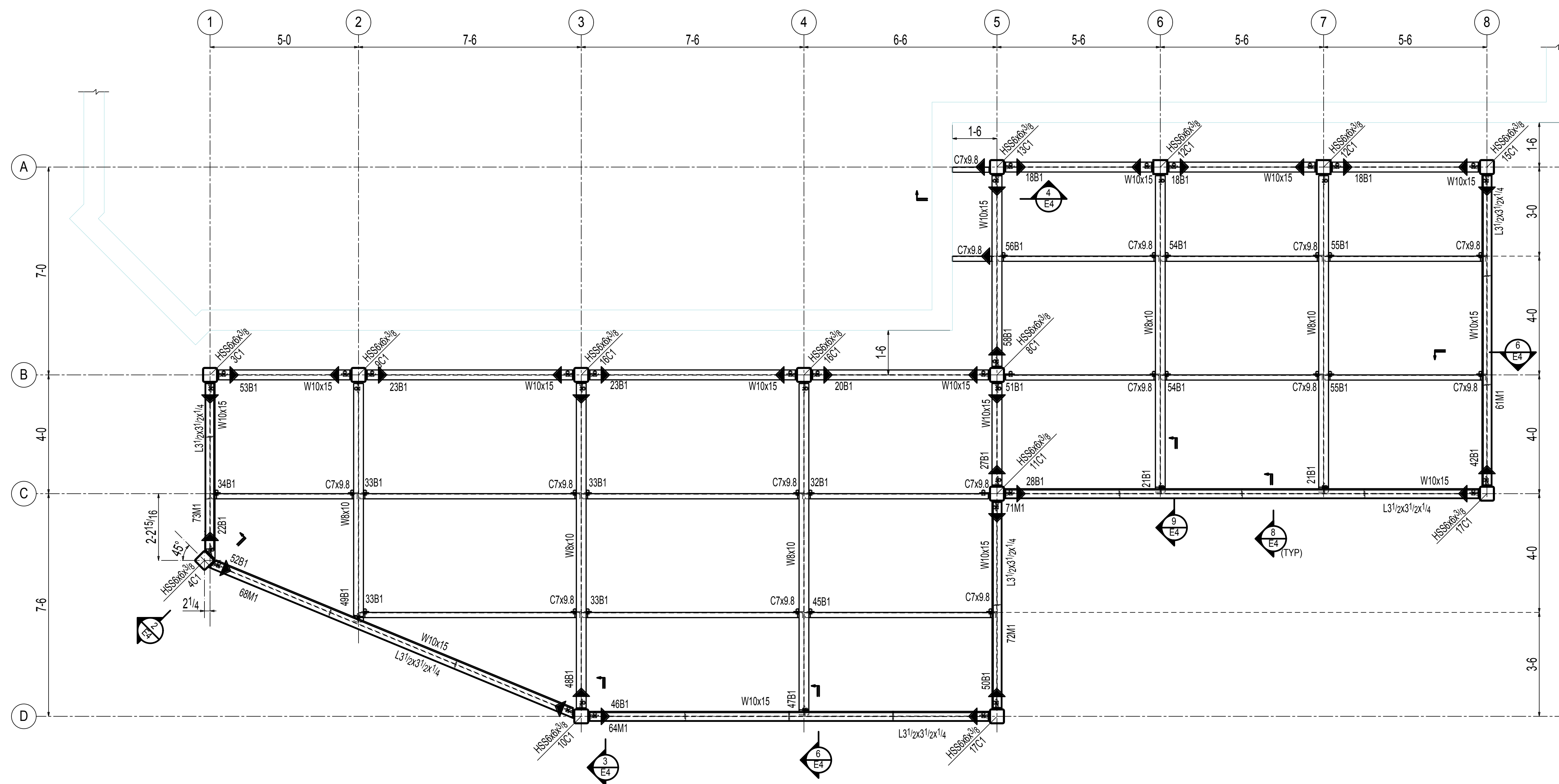

1ST STORY STEEL FRAMING PLAN

(REF DWG: S1.1)

- NOTES:
1. TOP OF STEEL ELEVATION = (103-8 1/2) U.N.O.
 2. (+/- X-X) = ABOVE/BELOW TOP OF STEEL ELEVATION.
 3. ◯ = MOMENT CONNECTIONS.

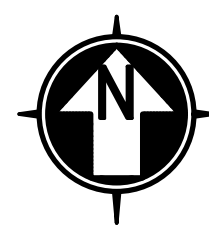
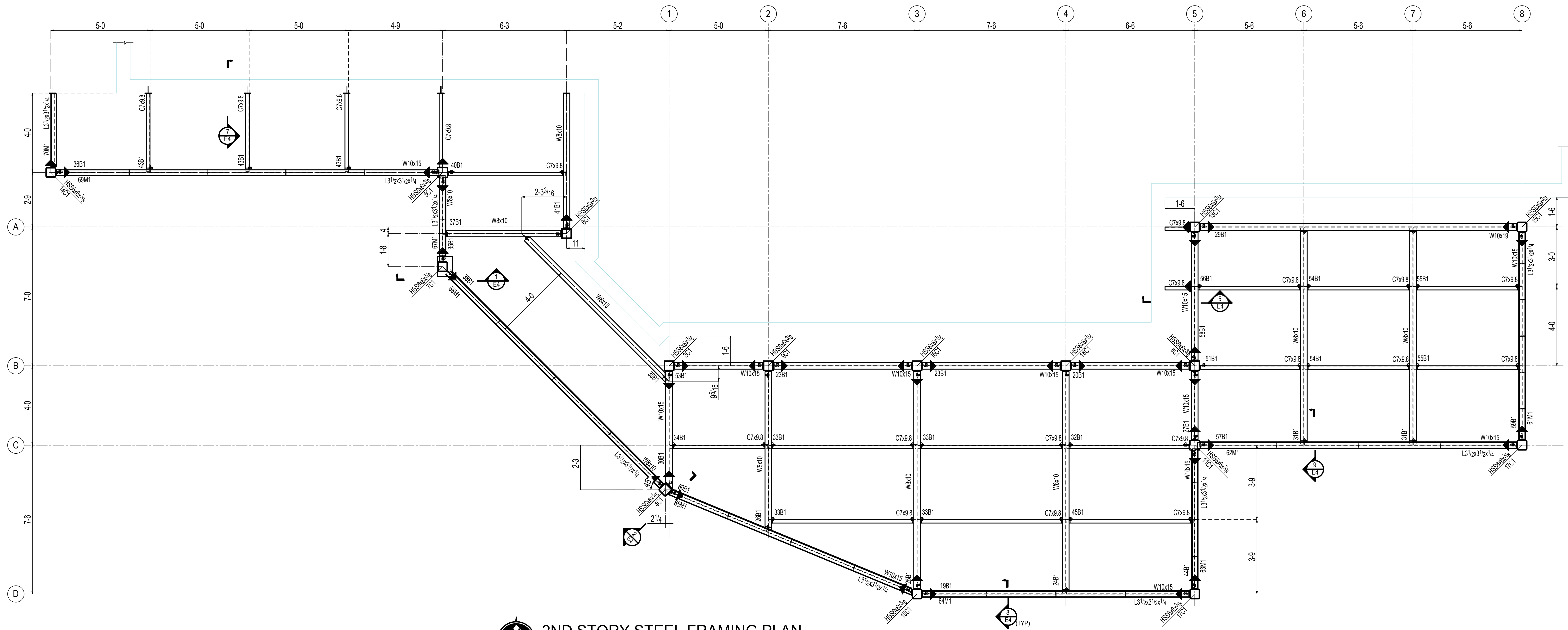

2ND STORY STEEL FRAMING PLAN

- NOTES:
 1. TOP OF STEEL ELEVATION = (113'-8 1/2") U.O.O.
 2. (+/- X-X) = ABOVE/BELOW TOP OF STEEL ELEVATION.
 3. = MOMENT CONNECTIONS.

(REF DWG:S1.2)

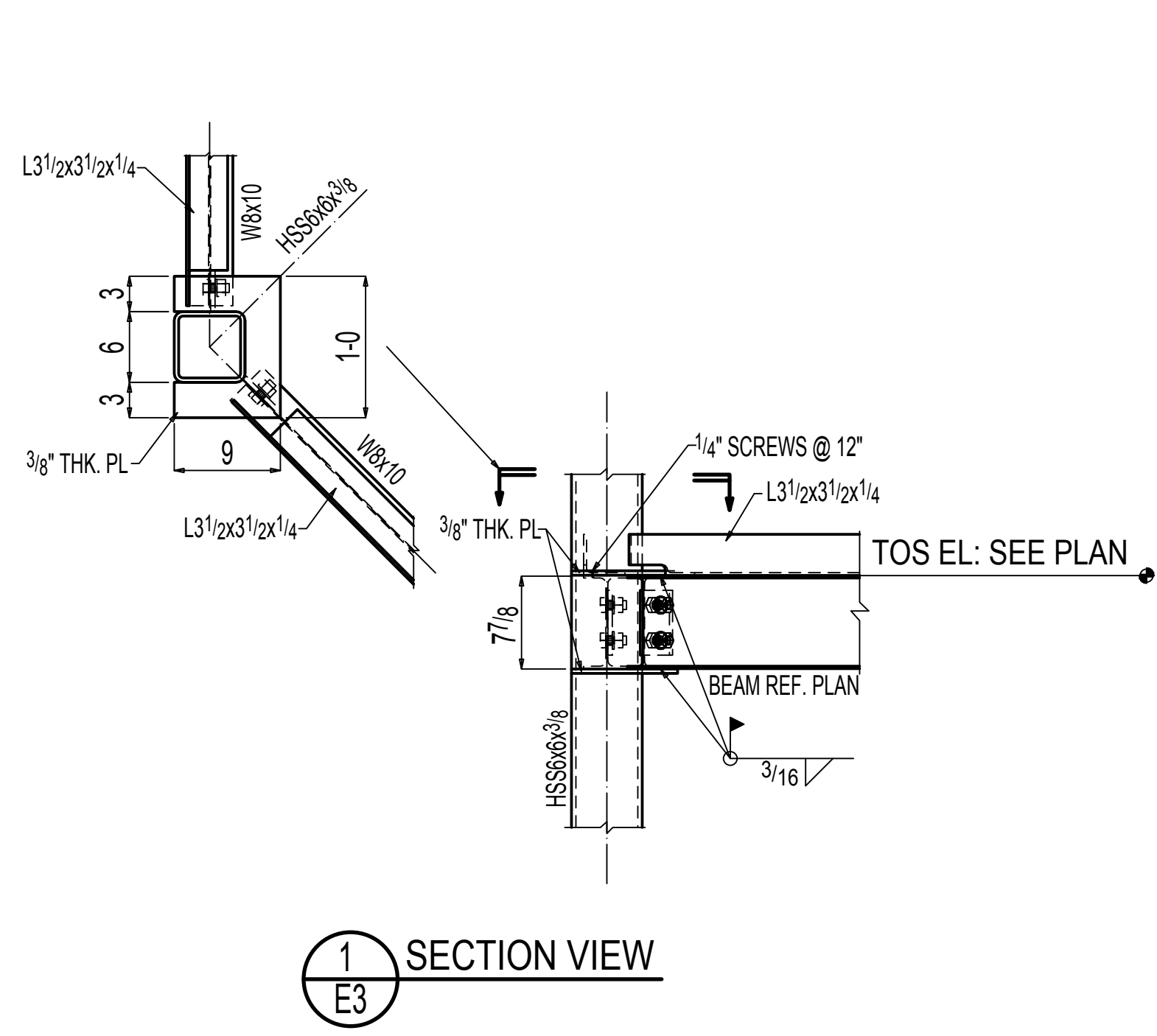

1 SECTION VIEW
E3

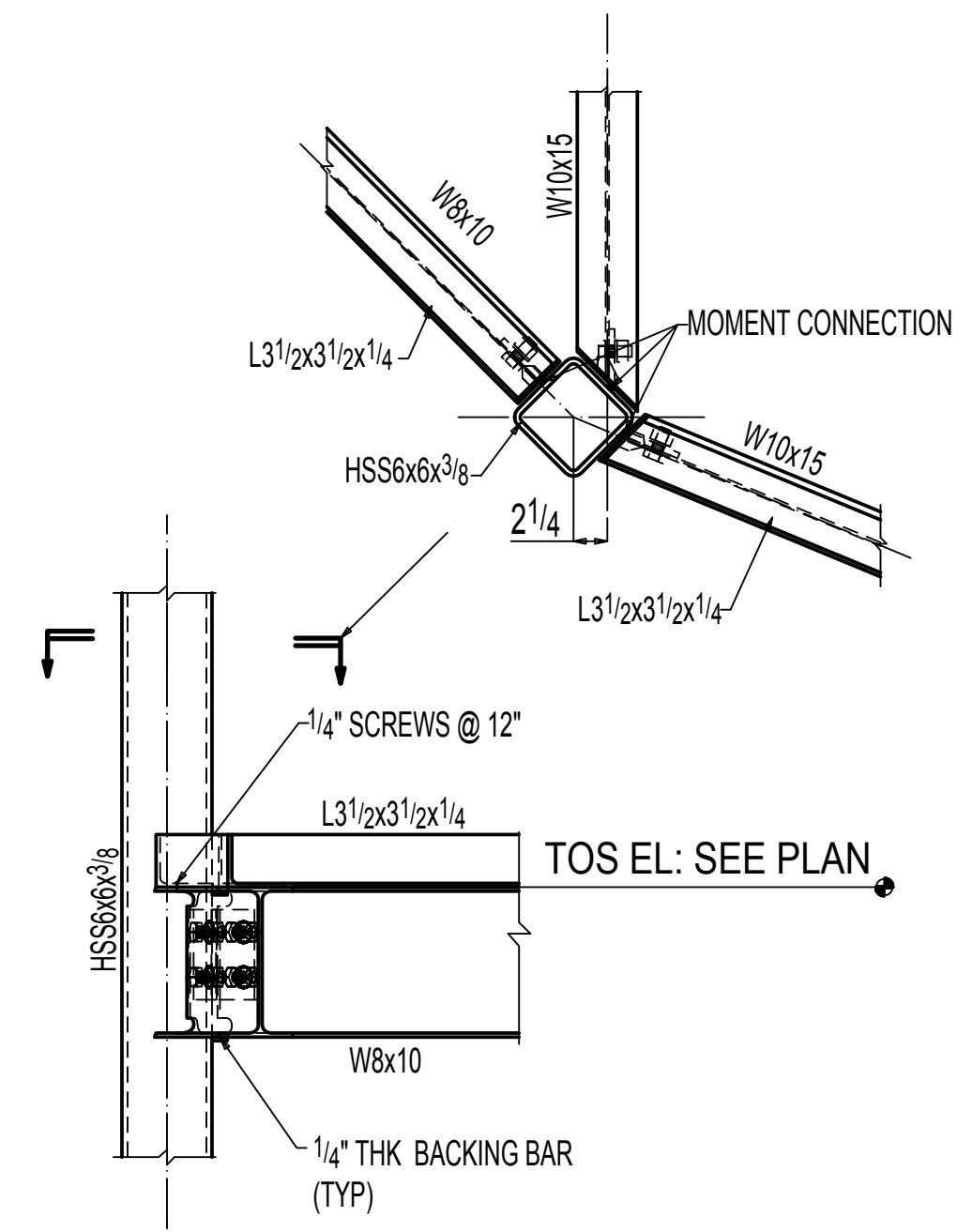

2 SECTION VIEW
E2, E3

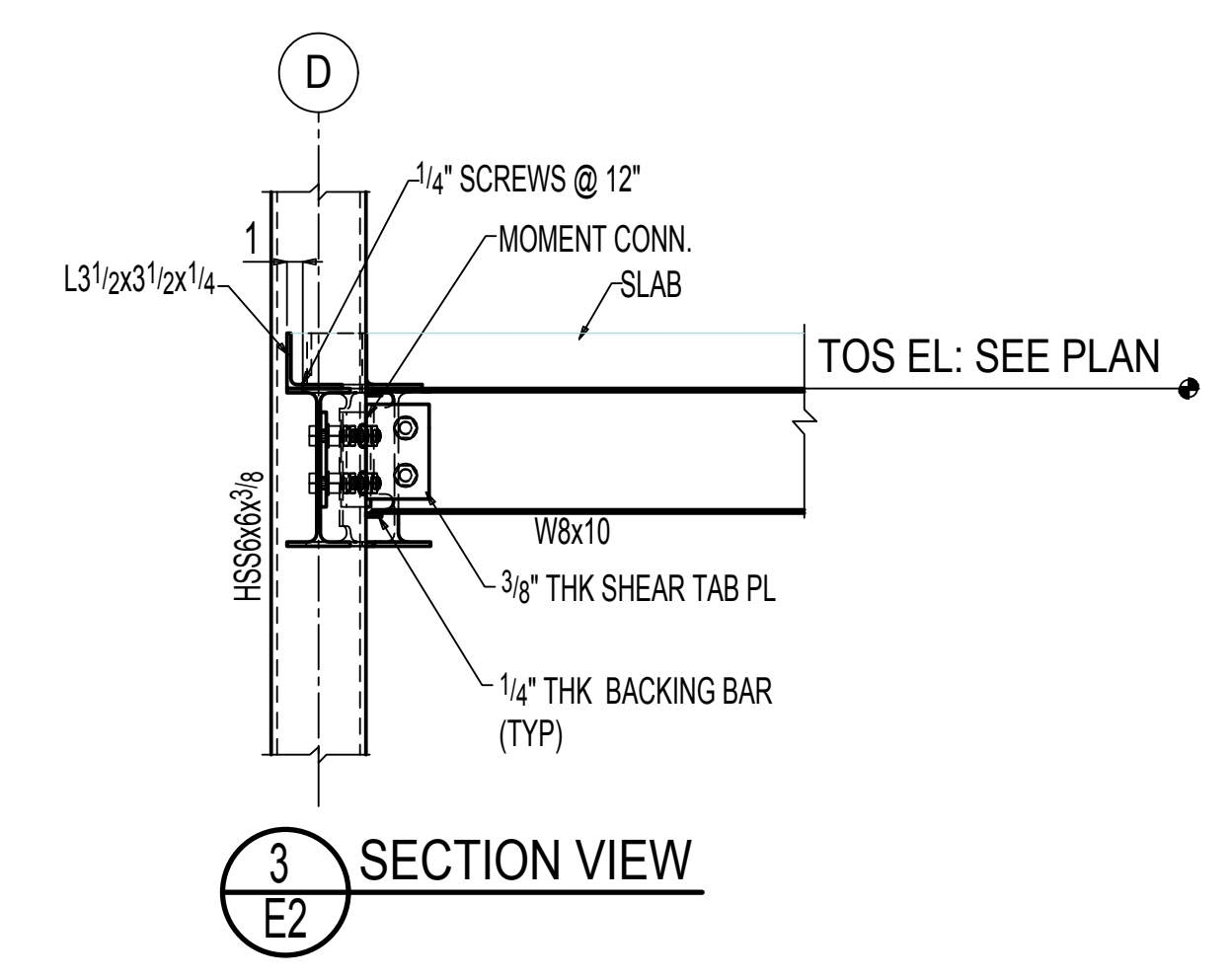

3 SECTION VIEW
E2

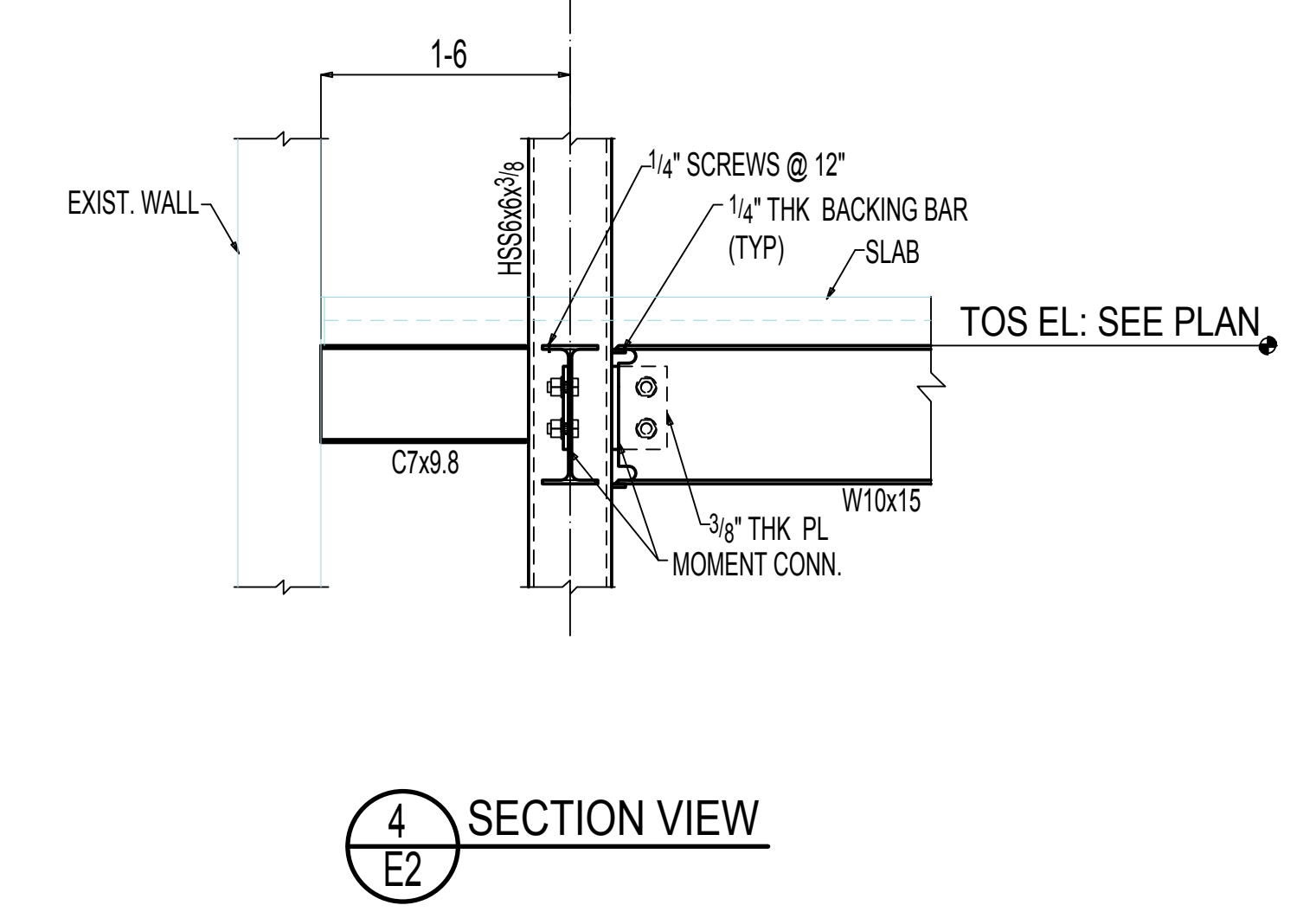

4 SECTION VIEW
E2

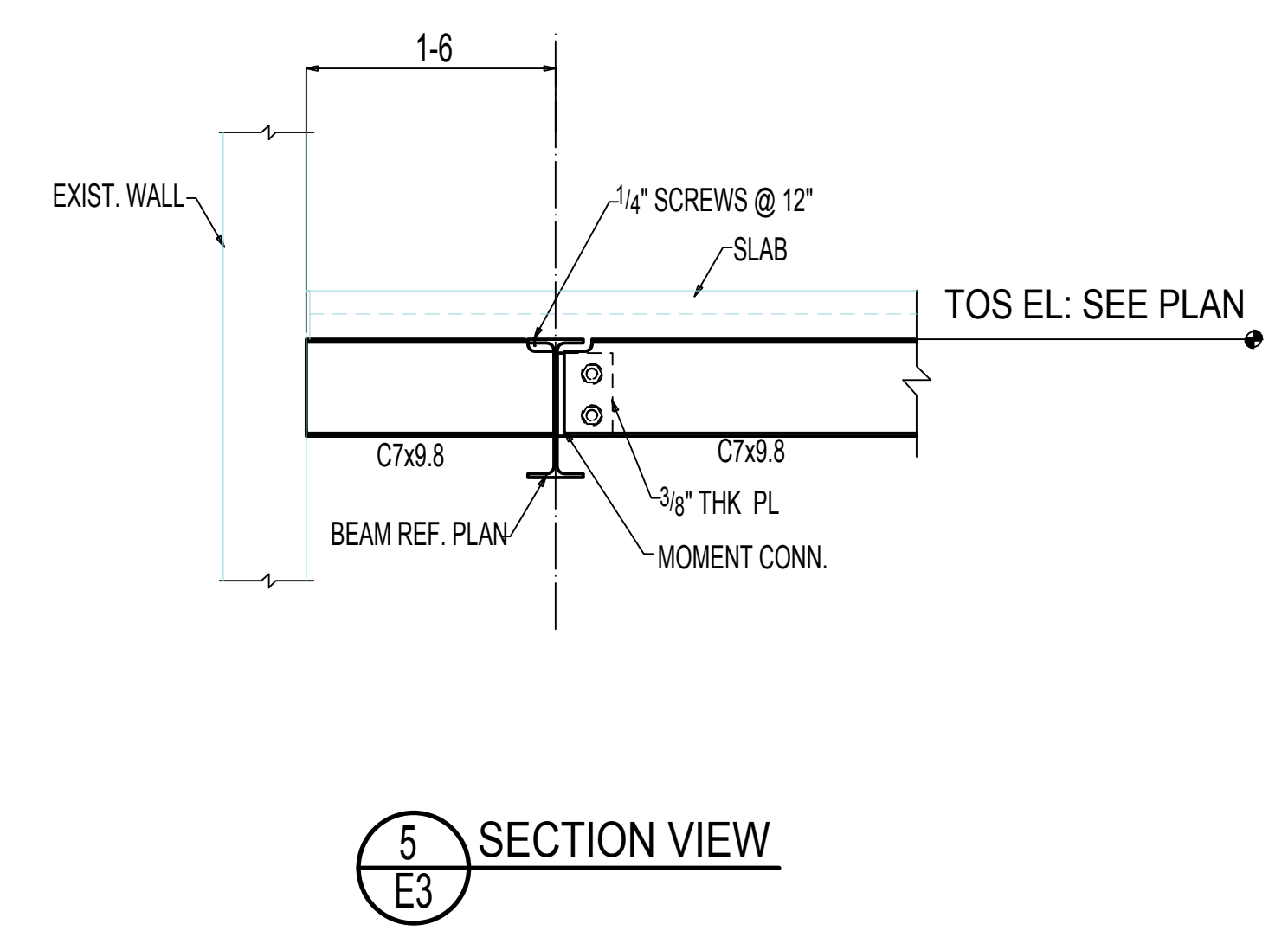

5 SECTION VIEW
E3

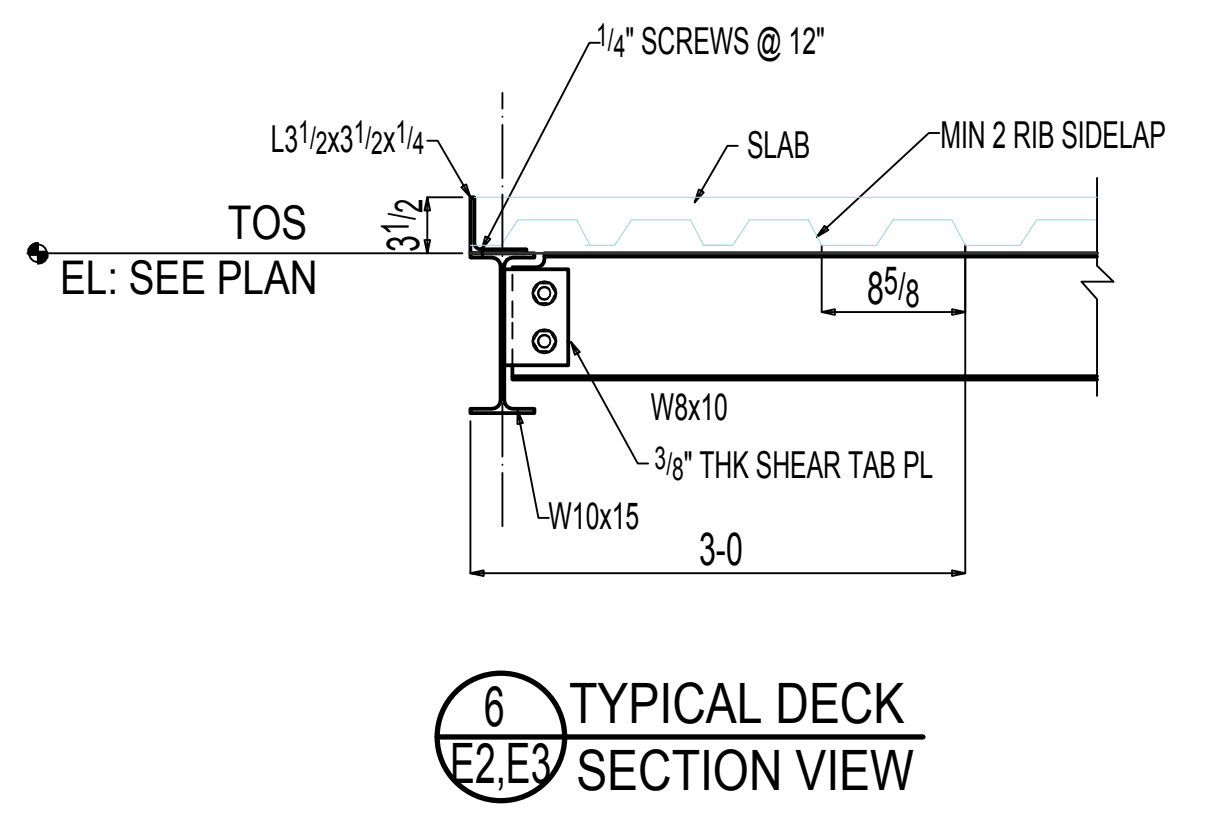

6 TYPICAL DECK SECTION VIEW
E2, E3

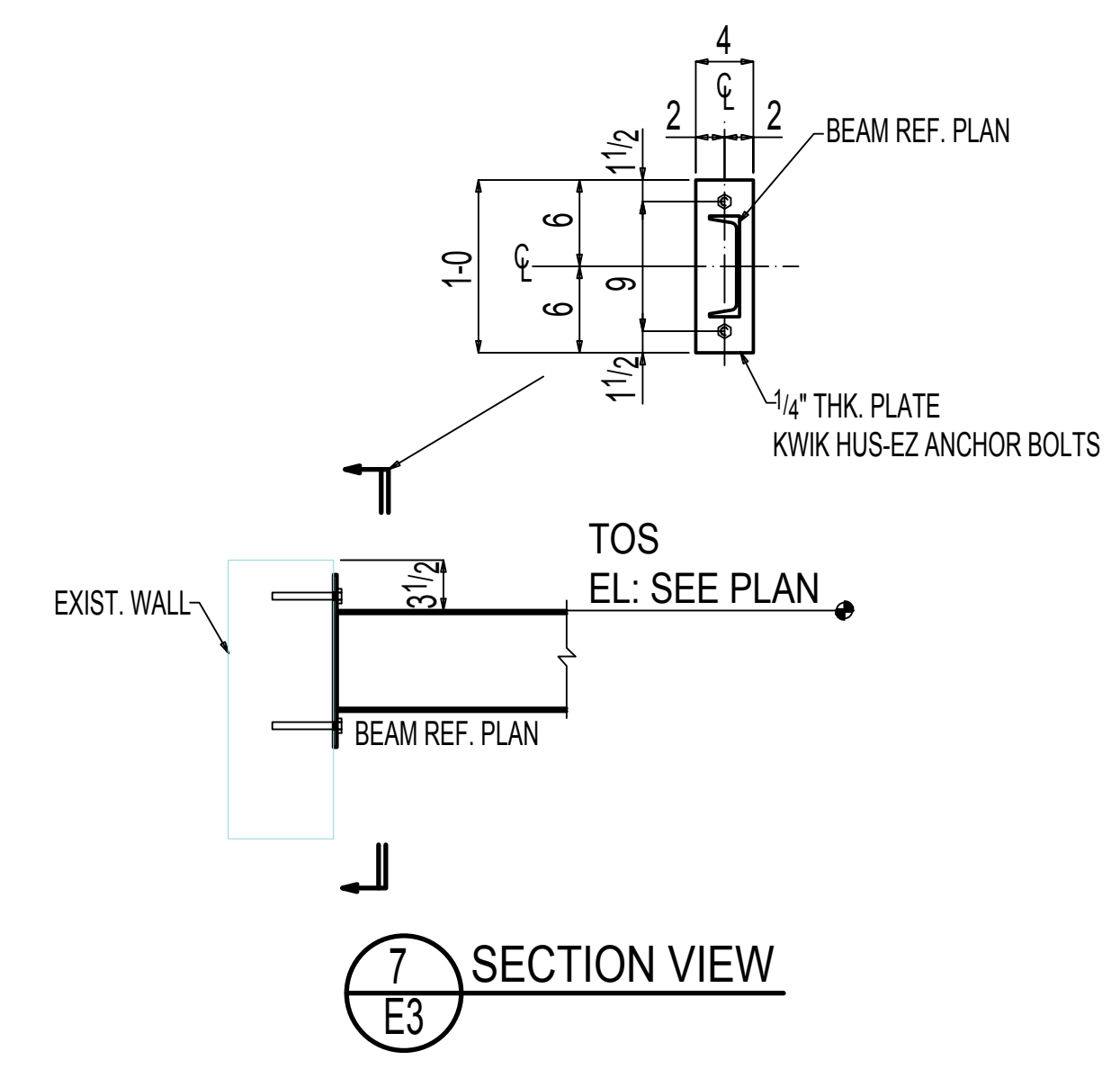

7 SECTION VIEW
E3

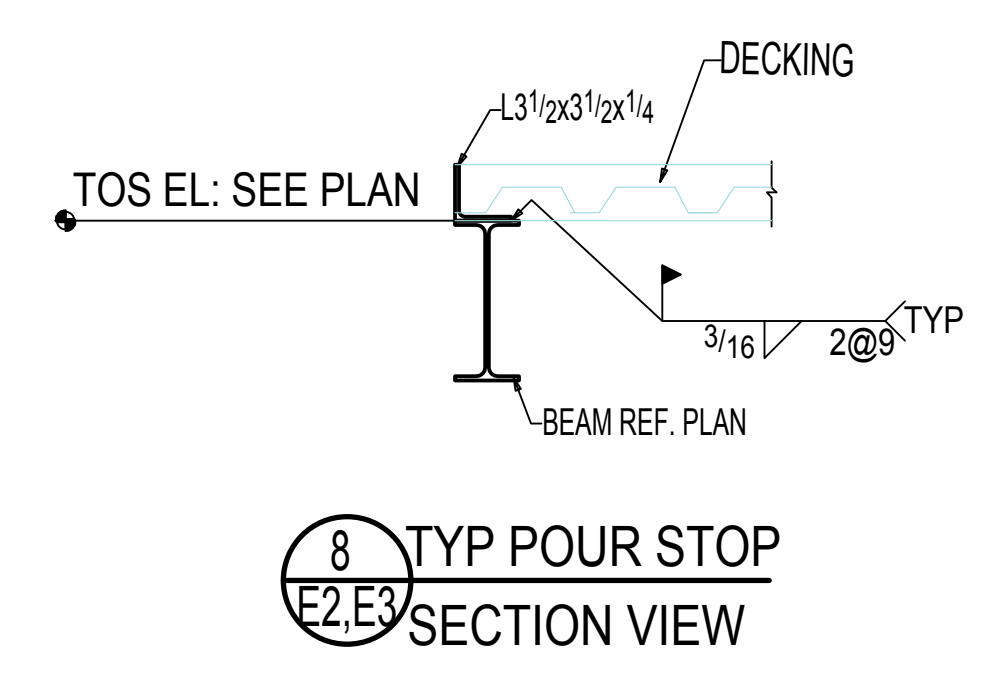

8 TYP POUR STOP SECTION VIEW
E2, E3

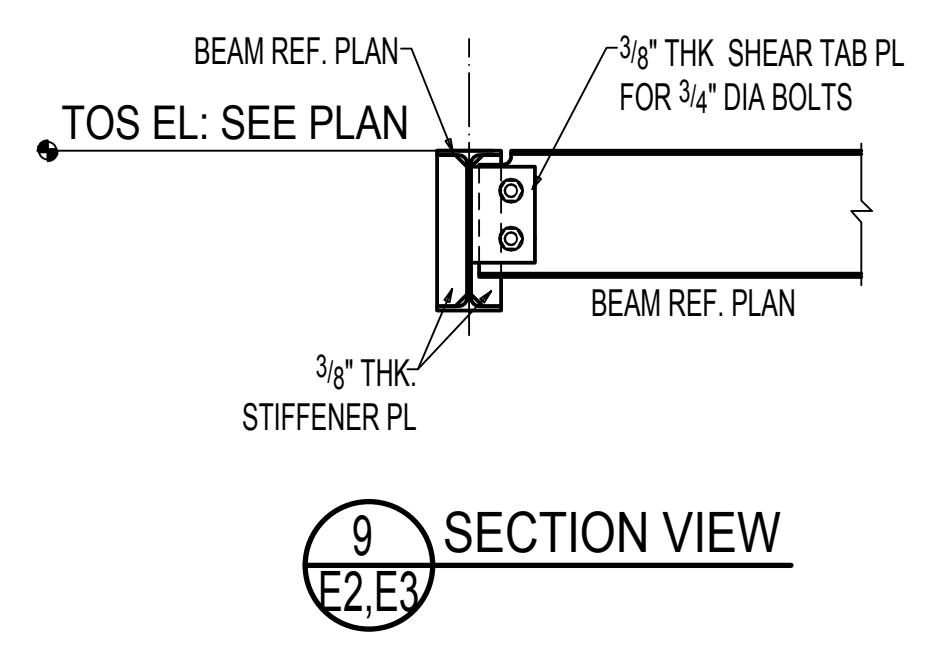

9 SECTION VIEW
E2, E3

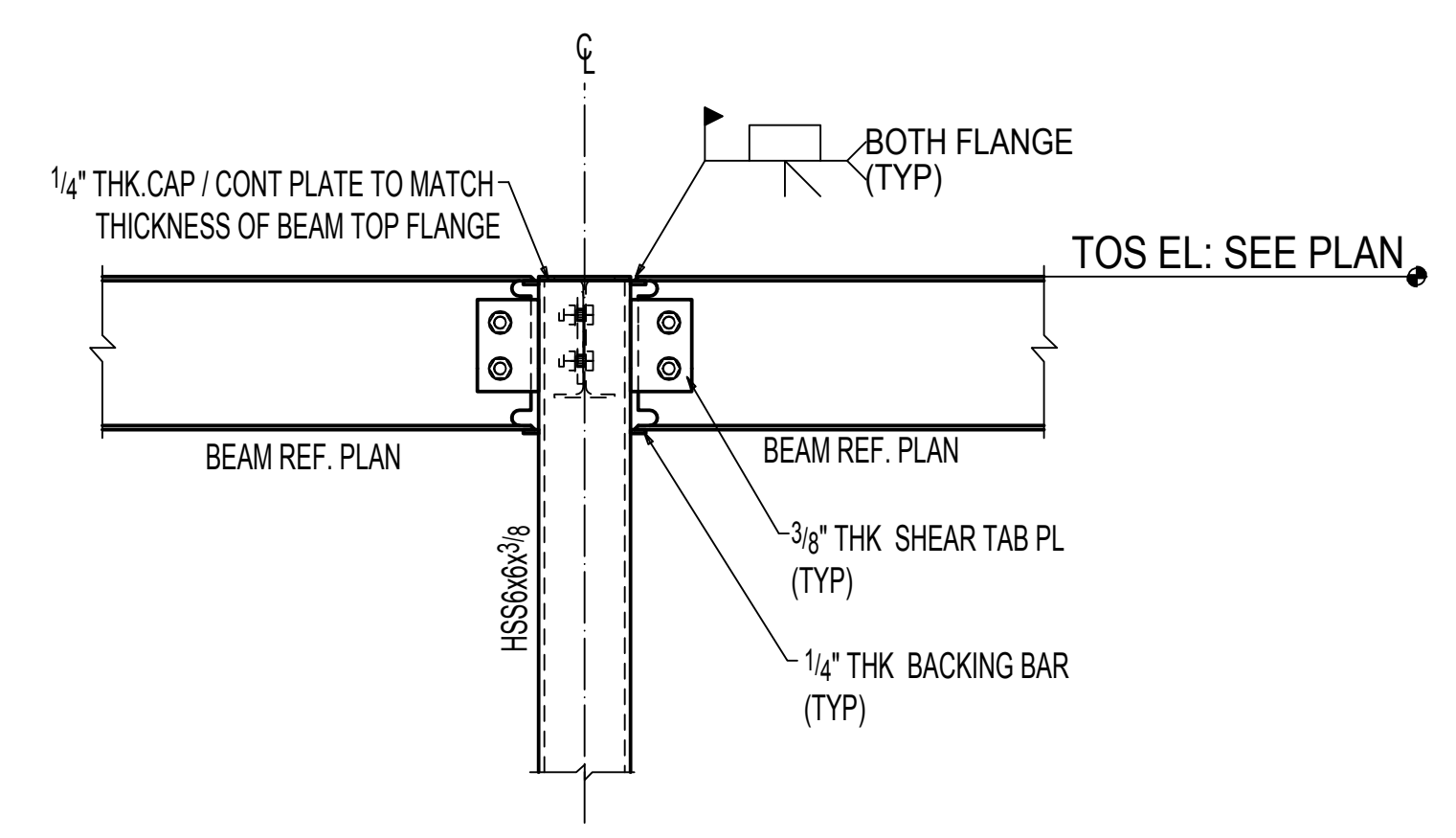

TYPICAL STEEL MOMENT CONNECTIONS